

Front view

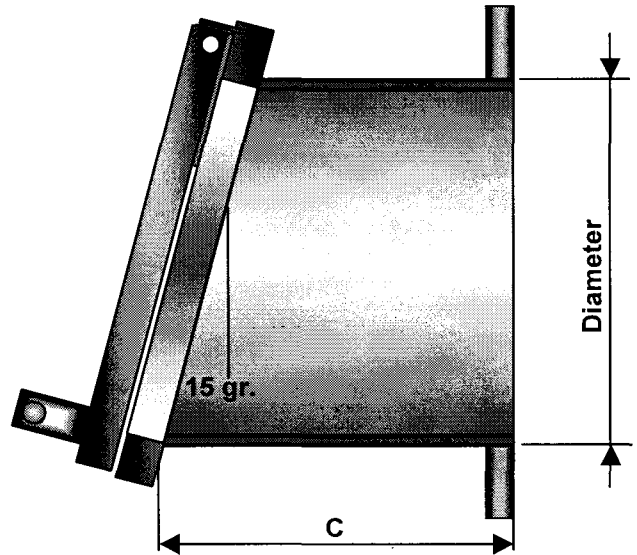

Section

Measurements in mm.

NW	Diam.	A	B	C	Weight in kg.
100	110	190	220	300	5
125	125	205	235	300	5
150	160	240	270	300	5
200	200	280	310	300	6
250	250	330	360	300	8
300	315	395	425	300	11
400	400	480	510	300	18
500	500	580	610	300	24

- Application** : End valve for surface water, sewers and other aggressive environments.
- Max. pressure** : 5 Metres head of water.
- Materials** : Valve- and backplate HDPE.
Solid axle and ballast weight stainless steel 316.
Valve seal EPDM compound is attached on the rear face of the flapvalve.
- Interface** : Between the valve flange (standard bore according to PN10) and the counter flange by means of a soft packing rubber material.
- Remarks** : Packing and mounting supplies are not delivered by KWT.
: Larger sizes and special shapes can be produced upon request.